

CAE_G-2RelNo4RelCo-01

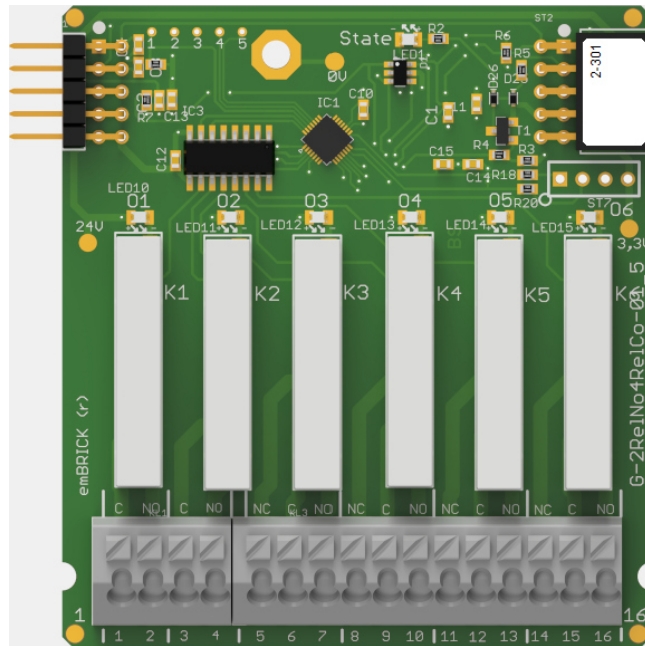

1.1 Description

ID: 2-301

Order No.: CAE_G-2RelNo4RelCo-01

Terminal: push-in (for $< 1.5\text{mm}^2$)

Size: 6 eU (66mm x 72mm)

BBFCP: 1-1-1

Weight: 60g

This Relay module includes six isolated Relays. Each can switch a current of max. 4A. The first two are closing contacts. The other four are changeover contacts. The state of each relay is visualized by an LED.

1.2 Connectors and Indication-/Operation-Elements

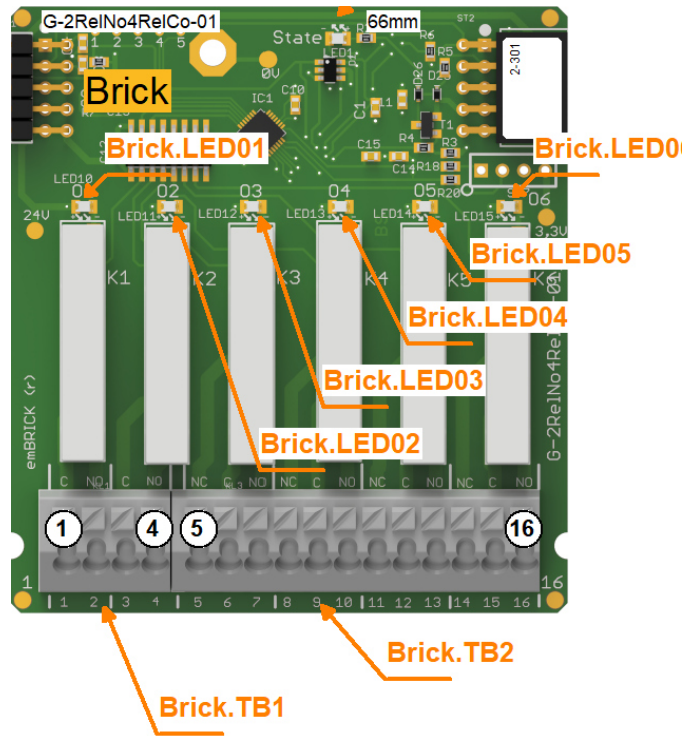

1.2.1 Terminal block (TB)

The following Illustration the technical details for Terminal blocks are listed. The location of a specific block is documented with the ID (left column) in the previous Illustrations.

ID	Model	Model / Series	Grid	Num. of term.	connection	elec. usage
Brick.TB01	Cage Terminal	WAGO250	3.5mm	4	up to 1.5mm ²	250V/8A AC, 24V/2A DC
Brick.TB02	Cage Terminal	WAGO250	3.5mm	12	up to 1.5mm ²	250V/8A AC, 24V/2A DC

1.2.2 Terminal assignment

Here the assignment of individual terminals and there affiliation to terminal blocks (Te block), terminal numbers (Te no.) and short description (T.desc.) aswell as there electrical function and usage are explained.

The associated mechanical and electrical properties are stated with the specific terminal block in the previous chapter. The position of a terminal is dedicated through the "Te block" and the actual terminal number (Te no.) or the therminal description (T.descr.) in the previous Illustration respectively.

In the column "usage" the technical-/ device-functional use is listed.

Te block	Te no.	T. descr.	Function	Usage
Brick.TB01	1	R	Relay, change over contact, isolated	Relay 1
Brick.TB01	2	NO	Relay, normally open contact, isolated	Relay 1
Brick.TB01	3	R	Relay, change over contact, isolated	Relay 2

Brick.TB01	4	NO	Relay, normally open contact, isolated	Relay 2
Brick.TB02	5	NC	Relay, normally close contact, isolated	Relay 3
Brick.TB02	6	C	Relay, change over contact, isolated	Relay 3
Brick.TB02	7	NO	Relay, normally open contact, isolated	Relay 3
Brick.TB02	8	NC	Relay, normally close contact, isolated	Relay 4
Brick.TB02	9	C	Relay, change over contact, isolated	Relay 4
Brick.TB02	10	NO	Relay, normally open contact, isolated	Relay 4
Brick.TB02	11	NC	Relay, normally close contact, isolated	Relay 5
Brick.TB02	12	C	Relay, change over contact, isolated	Relay 5
Brick.TB02	13	NO	Relay, normally open contact, isolated	Relay 5
Brick.TB02	14	NC	Relay, normally close contact, isolated	Relay 6
Brick.TB02	15	C	Relay, change over contact, isolated	Relay 6
Brick.TB02	16	NO	Relay, normally open contact, isolated	Relay 6

1.2.3 LED Indications

ID	Type	Specification	Type / Usage
Brick.LED01	SMD-LED	green	Shows state of Relay1
Brick.LED02	SMD-LED	green	Shows state of Relay2
Brick.LED03	SMD-LED	green	Shows state of Relay3
Brick.LED04	SMD-LED	green	Shows state of Relay4
Brick.LED05	SMD-LED	green	Shows state of Relay5
Brick.LED06	SMD-LED	green	Shows state of Relay6
Brick.StateLED	SMD-LED	yellow	communicationstate Brick

1.3 Input-/Output Scheme

The following diagram shows the adaption of the control unit. To avoid overlapping, some wires are displayed interrupted and dashed.

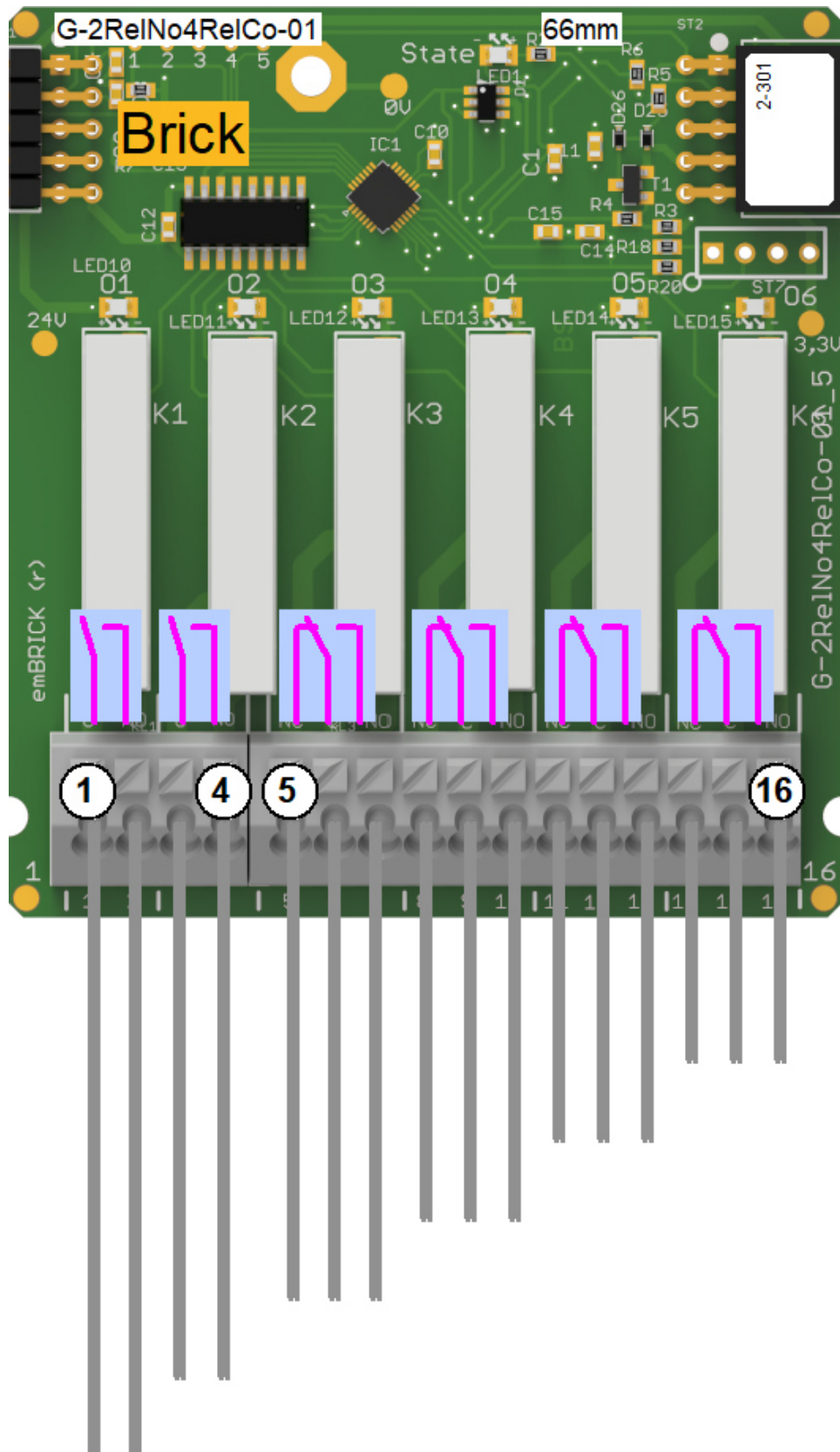

1.4 Technical Data

1.4.1 Digital Outputs

The control unit has the following digital outputs / switching outputs:

Identifier	Relay 1
Type	Relay, normally open contact, isolated
max. Switching Volt.	250V AC
max. Switching Cur.	5A AC, Contact 6A
max. Perm. Current	3A AC
nom. Cycles	see datasheet
Component	FTR, LYCA024V
Remark	

Identifier	Relay 2
Type	Relay, normally open contact, isolated
max. Switching Volt.	250V AC
max. Switching Cur.	5A AC, Contact 6A
max. Perm. Current	3A AC
nom. Cycles	see datasheet
Component	FTR, LYCA024V
Remark	

Identifier	Relay 3
Type	Relay, change over contact, isolated
max. Switching Volt.	250V AC
max. Switching Cur.	5A AC, Contact 6A
max. Perm. Current	3A AC
nom. Cycles	see datasheet
Component	FTR, LYCA024V
Remark	-

Identifier	Relay 4
Type	Relay, change over contact, isolated
max. Switching Volt.	250V AC
max. Switching Cur.	5A AC, Contact 6A
max. Perm. Current	3A AC
nom. Cycles	see datasheet
Component	FTR, LYCA024V
Remark	-

Identifier	Relay 5
Type	Relay, change over contact, isolated
max. Switching Volt.	250V AC
max. Switching Cur.	5A AC, Contact 6A
max. Perm. Current	3A AC
nom. Cycles	see datasheet
Component	FTR, LYCA024V
Remark	-

Identifier	Relay 6
Type	Relay, change over contact, isolated
max. Switching Volt.	250V AC
max. Switching Cur.	5A AC, Contact 6A
max. Perm. Current	3A AC
nom. Cycles	see datasheet
Component	FTR, LYCA024V
Remark	-

1.4.2 User Notes

- Blinking behavior StateLED:
Each Morse code is 3 seconds long!
not initialized = flashing continuously at approx. 5Hz
no communication = short-long-short
too little communication = short-short-short
disturbed communication = short-long-long
OK = continuous flashing at approx. 1Hz (0.6-1.5Hz)

1.4.3 Developer Notes

- All six relay have to operate on the same voltage level 230VAC or 24VAC or 24VDC. A mix-ture of different voltage levels is not allowed.
- The user have to install an appropriate fuse in the lines concerning the technical data below.
- This module support relay contacts. Depending on the electrical application, the user has to install sufficient additional components to fulfill the EMC-standads and the requirements of the relay producer (see relay datasheet), especially when driving inductive/capacitive or high inrush current loads.

1.5 Process Data Image

1.5.1 Outgoing Process Data (from bus master to this brick)

Byte	Function	rCAssign
00	Relay 1	...+eB_B0,0,0,...
+eB_B0,0,1,...
+eB_B0,0,2,...
+eB_B0,0,3,...
+eB_B0,0,4,...
	Relay 6	...+eB_B0,0,5,...
		...+eB_B0,0,6,...
		...+eB_B0,0,7,...

1.5.2 Incoming Process Data (from this brick to the bus master)

Byte	Function	rCAssign
	unused	

1.6 History

On the following page you will find a list of changes that have been made to the product.

1.6.1 History

Date	Entry scope (HW, SWappl, SWapi, Release)	Entry type (enhancement, improvement, bugfix, release)	Version	Status (development, implemented, tested)	Responsible	Reason for the modification	Items of modification	Impact for (end-)customer	Comment	Location in model/source
xxxx-xx-xx		Release	0.99	Tested	NSt					

For questions please contact:

emBrick GmbH	Alfred-Nobel-Straße 2 D-55411 Bingen am Rhein	+49 (0)6721-48035-70	https://www.embrick.de/ https://www.embrick.de/shop/ support@embrick.de
--------------	--	----------------------	--