

1.2 Connectors and Indication-/Operation-Elements

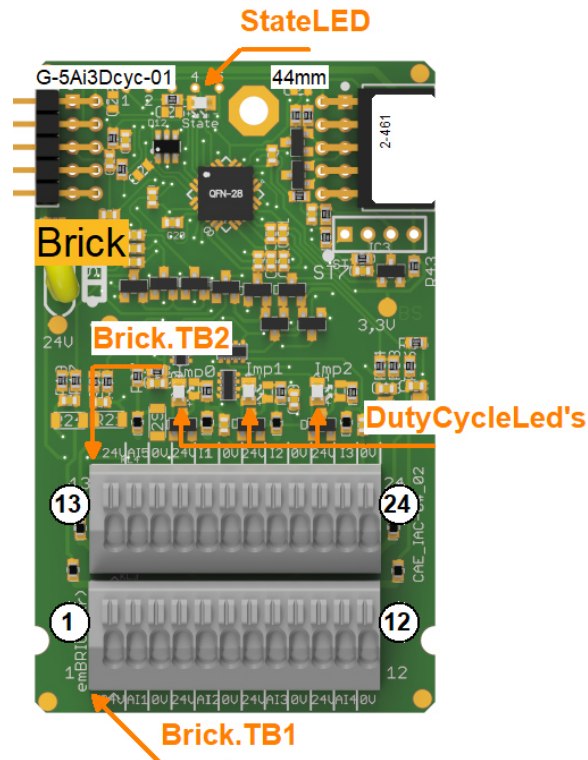

1.2.1 Terminal block (TB)

The following Illustration the technical details for Terminal blocks are listed. The location of a specific block is documented with the ID (left column) in the previous Illustrations.

ID	Model	Model / Series	Grid	Num. of term.	connection	elec. usage
Brick.TB1	Cage Terminal	WAGO250	2.5mm	12	up to 0.5mm ² or 0,8mm	signal level
Brick.TB2	Cage Terminal	WAGO250	2.5mm	12	up to 0.5mm ² or 0,8mm	signal level

1.2.2 Terminal assignment

Here the assignment of individual terminals and there affiliation to terminal blocks (Te block), terminal numbers (Te no.) and short description (T.desc.) aswell as there electrical function and usage are explained.

The associated mechanical and electrical properties are stated with the specific terminal block in the previous chapter. The position of a terminal is dedicated through the "Te block" and the actual terminal number (Te no.) or the therminal description (T.descr.) in the previous Illustration respectively.

In the column "usage" the technical-/ device-functional use is listed.

Te block	Te no.	T. descr.	Function	Usage
Brick.TB00	0	24V	Sensor supply +24V	Ai1

Brick.TB00	1	IN	Input	Ai1
Brick.TB00	2	0V	Ground	Ai1
Brick.TB00	3	24V	Sensor supply +24V	Ai2
Brick.TB00	4	IN	Input	Ai2
Brick.TB00	5	0V	Ground	Ai2
Brick.TB00	6	24V	Sensor supply +24V	Ai3
Brick.TB00	7	IN	Input	Ai3
Brick.TB00	8	0V	Ground	Ai3
Brick.TB00	9	24V	Sensor supply +24V	Ai4
Brick.TB00	10	IN	Input	Ai4
Brick.TB00	11	0V	Ground	Ai4
Brick.TB00	12	24V	Sensor supply +24V	Ai5
Brick.TB00	13	IN	Input	Ai5
Brick.TB00	14	0V	Ground	Ai5
Brick.TB00	15	V+	Sensor supply +24V	Dcyc1
Brick.TB00	16	In	Input	Dcyc1
Brick.TB00	17	0V	Ground	Dcyc1
Brick.TB00	18	V+	Sensor supply +24V	Dcyc2
Brick.TB00	19	In	Input	Dcyc2
Brick.TB00	20	0V	Ground	Dcyc2
Brick.TB00	21	V+	Sensor supply +24V	Dcyc3
Brick.TB00	22	In	Input	Dcyc3
Brick.TB00	23	0V	Ground	Dcyc3

1.2.3 LED Indications

ID	Type	Specification	Type / Usage
Brick.StateLED	SMD-LED	yellow	communicationstate Brick

1.3 Input-/Output Scheme

The following diagram shows the adaption of the control unit. To avoid overlapping, some wires are displayed interrupted and dashed.

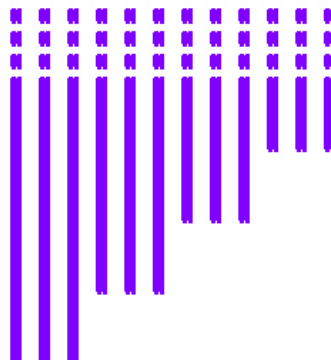
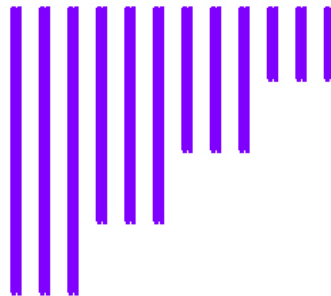
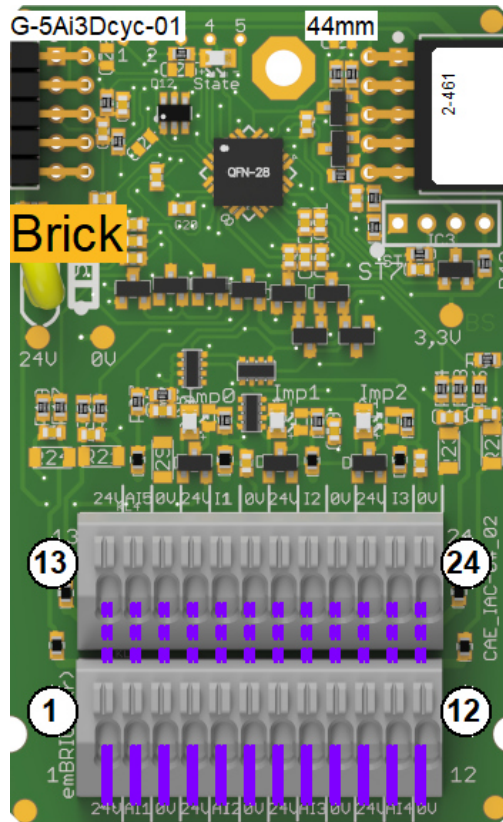

1.4 Technical Data

1.4.1 Analog Inputs

The control unit has the following analogue inputs / measuring inputs:

Identifier	Ai1
Type	Voltage Input
Range	0 ... 2.5V, 2/3-wire
Input/Load Resistor	>50k
Resolution	
Accuracy	0.5%
Linearity	0.2%
Filter	100Hz
Linearization	
Model / Series	
Remark	Sensor power supply (24V) is provided; note overall capacity

Identifier	Ai2
Type	Voltage Input
Range	0 ... 2.5V, 2/3-wire
Input/Load Resistor	>50k
Resolution	
Accuracy	0.5%
Linearity	0.2%
Filter	100Hz
Linearization	
Model / Series	
Remark	Sensor power supply (24V) is provided; note overall capacity

Identifier	Ai3
Type	Voltage Input
Range	0 ... 2.5V, 2/3-wire
Input/Load Resistor	>50k
Resolution	
Accuracy	0.5%
Linearity	0.2%
Filter	100Hz
Linearization	
Model / Series	
Remark	Sensor power supply (24V) is provided; note overall capacity

Identifier	Ai4
Type	Voltage Input
Range	0 ... 2.5V, 2/3-wire
Input/Load Resistor	>50k
Resolution	
Accuracy	0.5%
Linearity	0.2%
Filter	100Hz

Linearization	
Model / Series	
Remark	Sensor power supply (24V) is provided; note overall capacity

Identifier	Ai5
Type	Voltage Input
Range	0 ... 2.5V, 2/3-wire
Input/Load Resistor	>50k
Resolution	
Accuracy	0.5%
Linearity	0.2%
Filter	100Hz
Linearization	
Model / Series	
Remark	Sensor power supply (24V) is provided; note overall capacity

1.4.2 Pulse and Counting Inputs

The control unit has the following pulse inputs / counter inputs:

Identifier	Dcyc1
Type	Impuls/Digital input, universal 2/3 wire
Threshold	0.6 / 1V
Input Circuit	n-switching
Sensitivity	rising slope
Gate Time (Frequ.Mode)	??? t.b.d.
Resolution (Per.Mode)	??? t.b.d.
Filter	hardware, 1st order, fcut off = approx. 1.5kHz
Component	-
Remark	Sensor power supply (24V) is provided; note overall capacity

Identifier	Dcyc2
Type	Impuls/Digital input, universal 2/3 wire
Threshold	0.6 / 1V
Input Circuit	n-switching
Sensitivity	rising slope
Gate Time (Frequ.Mode)	??? t.b.d.
Resolution (Per.Mode)	??? t.b.d.
Filter	hardware, 1st order, fcut off = approx. 1.5kHz
Component	-
Remark	Sensor power supply (24V) is provided; note overall capacity

Identifier	Dcyc3
Type	Impuls/Digital input, universal 2/3 wire
Threshold	0.6 / 1V
Input Circuit	n-switching

Sensitivity	rising slope
Gate Time (Frequ.Mode)	??? t.b.d.
Resolution (Per.Mode)	??? t.b.d.
Filter	hardware, 1st order, fcut off = approx. 1.5kHz
Component	-
Remark	Sensor power supply (24V) is provided; note overall capacity

1.4.3 User Notes

- Blinking behavior StateLED:
 - Each Morse code is 3 seconds long!
 - not initialized = flashing continuously at approx. 5Hz
 - no communication = short-long-short
 - too little communication = short-short-short
 - disturbed communication = short-long-long
 - OK = continuous flashing at approx. 1Hz (0.6-1.5Hz)

1.5 History

On the following page you will find a list of changes that have been made to the product.

1.5.1 History

Date	Entry scope (HW, SWappl, SWapi, Release)	Entry type (enhancement, improvement, bugfix, release)	Version	Status (development, implemented, tested)	Responsible	Reason for the modification	Items of modification	Impact for (end-)customer	Comment	Location in model/source
xxxx-xx-xx		Release	0.99	Tested	NSt					

For questions please contact:

emBrick GmbH	Alfred-Nobel-Straße 2 D-55411 Bingen am Rhein	+49 (0)6721-48035-70	https://www.embrick.de/ https://www.embrick.de/shop/ support@embrick.de
--------------	--	----------------------	--