

# CAE\_G-5Ai3Imp-01

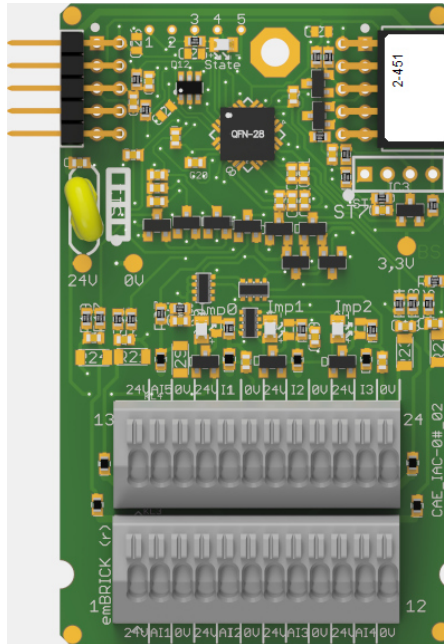

## 1.1 Description

ID: 2-451

Order No.: CAE\_G-5Ai3Imp-01 (-p)

Terminal: push-in (for  $\leq 0.5\text{mm}^2$ )

Size: 4 eU (44mm x 72mm)

BBFCP: 1-1-1

Weight: 30g

This module includes 5 analog inputs and 3 pulse inputs.

The analog inputs are voltage or current inputs depending on the variant in use.

The pulse inputs always measure the high time of the signal and frequencies up to 500Hz.

## 1.2 Connectors and Indication-/Operation-Elements

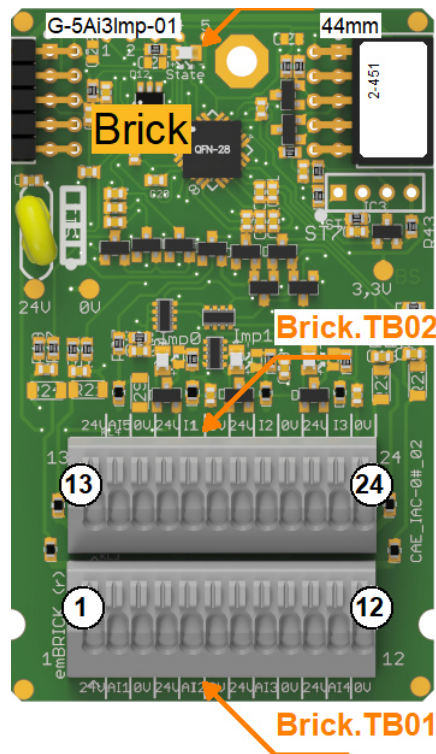

### 1.2.1 Terminal block (TB)

The following Illustration the technical details for Terminal blocks are listed. The location of a specific block is documented with the ID (left coloumn) in the preavious Illustrations.

ID	Model	Model / Series	Grid	Num. of term.	connection	elec. usage
Brick.TB1	Cage Terminal	WAGO250	2.5mm	12	up to 0.5mm <sup>2</sup> or 0,8mm	signal level
Brick.TB2	Cage Terminal	WAGO250	2.5mm	12	up to 0.5mm <sup>2</sup> or 0,8mm	signal level

### 1.2.2 Terminal assignment

Here the assignment of individual terminals and there affiliation to terminal blocks (Te block), terminal numbers (Te no.) and short description (T.desc.) aswell as there electrical function and usage are explained.

The associated mechanical and electrical properties are stated with the specific terminal block in the previous chapter. The position of a terminal is dedicated through the "Te block" and the actual terminal number (Te no.) or the therminal description (T.desc.) in the previous Illustration respectively.

In the coloumn "usage" the technical-/ device-functional use is listed.

Te block	Te no.	T. descr.	Function	Usage
Brick.TB00	0	24V	Sensor supply +24V	Ai1

Brick.TB00	1	IN	Input	Ai1
Brick.TB00	2	0V	Ground	Ai1
Brick.TB00	3	24V	Sensor supply +24V	Ai2
Brick.TB00	4	IN	Input	Ai2
Brick.TB00	5	0V	Ground	Ai2
Brick.TB00	6	24V	Sensor supply +24V	Ai3
Brick.TB00	7	IN	Input	Ai3
Brick.TB00	8	0V	Ground	Ai3
Brick.TB00	9	24V	Sensor supply +24V	Ai4
Brick.TB00	10	IN	Input	Ai4
Brick.TB00	11	0V	Ground	Ai4
Brick.TB00	12	24V	Sensor supply +24V	Ai5
Brick.TB00	13	IN	Input	Ai5
Brick.TB00	14	0V	Ground	Ai5
Brick.TB00	15	V+	Sensor supply +24V	Imp1
Brick.TB00	16	In	Input	Imp1
Brick.TB00	17	0V	Ground	Imp1
Brick.TB00	18	V+	Sensor supply +24V	Imp2
Brick.TB00	19	In	Input	Imp2
Brick.TB00	20	0V	Ground	Imp2
Brick.TB00	21	V+	Sensor supply +24V	Imp3
Brick.TB00	22	In	Input	Imp3
Brick.TB00	23	0V	Ground	Imp3

### 1.2.3 LED Indications

ID	Type	Specification	Type / Usage
Brick.StateLED	SMD-LED	yellow	communicationstate Brick

### 1.3 Input-/Output Scheme

The following diagram shows the adaption of the control unit. To avoid overlapping, some wires are displayed interrupted and dashed.

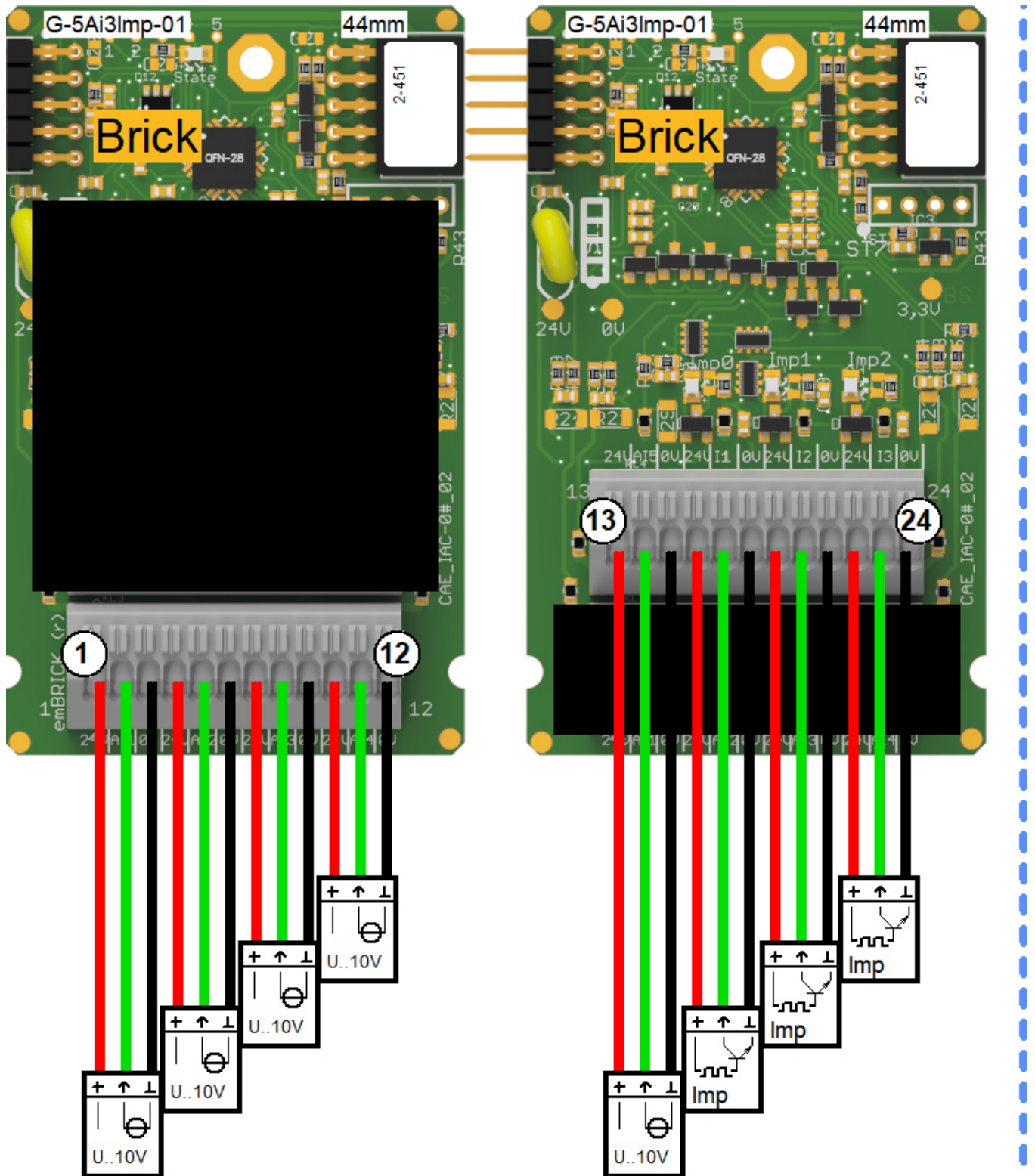

## 1.4 Technical Data

### 1.4.1 Analog Inputs

The control unit has the following analogue inputs / measuring inputs:

Identifier	Ai1
Type	Voltage Input
Range	0 ... 10V
Input/Load Resistor	>50k
Resolution	
Accuracy	0.5%
Linearity	0.2%
Filter	100Hz
Linearization	
Model / Series	
Remark	Sensor power supply (24V) is provided; note overall capacity

Identifier	Ai2
Type	Voltage Input
Range	0 ... 10V
Input/Load Resistor	>50k
Resolution	
Accuracy	0.5%
Linearity	0.2%
Filter	100Hz
Linearization	
Model / Series	
Remark	Sensor power supply (24V) is provided; note overall capacity

Identifier	Ai3
Type	Voltage Input
Range	0 ... 10V
Input/Load Resistor	>50k
Resolution	
Accuracy	0.5%
Linearity	0.2%
Filter	100Hz
Linearization	
Model / Series	
Remark	Sensor power supply (24V) is provided; note overall capacity

Identifier	Ai4
Type	Voltage Input
Range	0 ... 10V
Input/Load Resistor	>50k
Resolution	
Accuracy	0.5%
Linearity	0.2%
Filter	100Hz

Linearization	
Model / Series	
Remark	Sensor power supply (24V) is provided; note overall capacity

Identifier	Ai5
Type	Voltage Input
Range	0 ... 10V
Input/Load Resistor	>50k
Resolution	
Accuracy	0.5%
Linearity	0.2%
Filter	100Hz
Linearization	
Model / Series	
Remark	Sensor power supply (24V) is provided; note overall capacity

### 1.4.2 Pulse and Counting Inputs

The control unit has the following pulse inputs / counter inputs:

Identifier	Imp1
Type	Impuls/Digital input, universal 2/3 wire
Threshold	0.6 / 1V
Input Circuit	n-switching
Sensitivity	rising slope
Gate Time (Frequ.Mode)	10ms ... 65s
Resolution (Per.Mode)	1 ... 50ms
Filter	hardware, 1st order, fcut off = approx. 1.5kHz
Component	-
Remark	Sensor power supply (24V) is provided; note overall capacity

Identifier	Imp2
Type	Impuls/Digital input, universal 2/3 wire
Threshold	0.6 / 1V
Input Circuit	n-switching
Sensitivity	rising slope
Gate Time (Frequ.Mode)	10ms ... 65s
Resolution (Per.Mode)	1 ... 50ms
Filter	hardware, 1st order, fcut off = approx. 1.5kHz
Component	-
Remark	Sensor power supply (24V) is provided; note overall capacity

Identifier	Imp3
Type	Impuls/Digital input, universal 2/3 wire
Threshold	0.6 / 1V
Input Circuit	n-switching

Sensitivity	rising slope
Gate Time (Frequ.Mode)	10ms ... 65s
Resolution (Per.Mode)	1 ... 50ms
Filter	hardware, 1st order, fcut off = approx. 1.5kHz
Component	-
Remark	Sensor power supply (24V) is provided; note overall capacity

### 1.4.3 User Notes

- Blinking behavior StateLED:  
Each Morse code is 3 seconds long!  
not initialized = flashing continuously at approx. 5Hz  
no communication = short-long-short  
too little communication = short-short-short  
disturbed communication = short-long-long  
OK = continuous flashing at approx. 1Hz (0.6-1.5Hz)

### 1.4.4 Developer Notes

- The voltage range of the analog inputs (10V variant) can be expanded by an external series resistor in the input line. Therefore the input resistance of the board is exact 104kOhm, the external resistor has to be also 104kOhm for every 10V range expansion. e.g. for a range expansion to 0...50V you have to use a calculated series resistor of  $4 \times 104\text{kOhm} = 416\text{ kOhm}$  (use 390kOhm + 27kOhm of the E12 row). The filter behavior will not be changed.

## 1.5 History

On the following page you will find a list of changes that have been made to the product.

### 1.5.1 History

Date	Entry scope (HW, SWappl, SWapi, Release)	Entry type (enhancement, improvement, bugfix, release)	Version	Status (development, implemented, tested)	Responsible	Reason for the modification	Items of modification	Impact for (end-)customer	Comment	Location in model/source
xxxx-xx-xx		Release	0.99	Tested	NSt					

For questions please contact:

emBrick GmbH	Alfred-Nobel-Straße 2 D-55411 Bingen am Rhein	+49 (0)6721-48035-70	<a href="https://www.embrick.de/">https://www.embrick.de/</a> <a href="https://www.embrick.de/shop/">https://www.embrick.de/shop/</a> <a href="mailto:support@embrick.de">support@embrick.de</a>
--------------	--	----------------------	--