

CAE_P-112RelPow-01

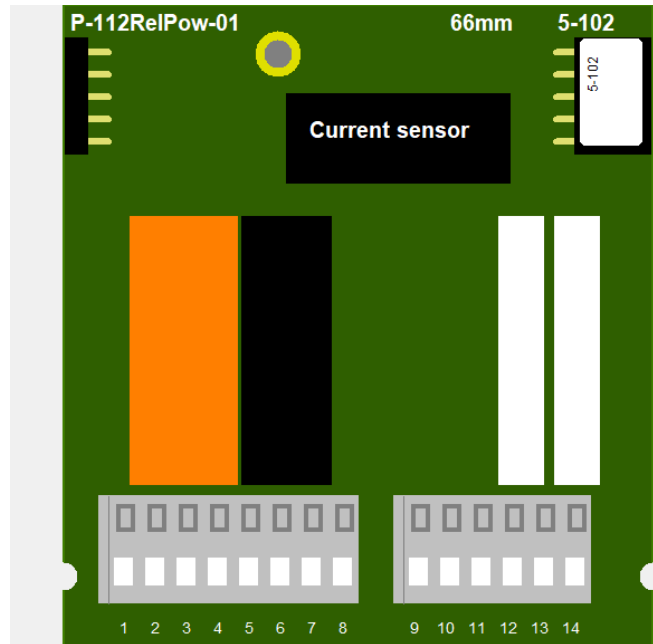

1.1 Description

ID: 5-102

Order No.: CAE_P-112RelPow-01

Terminal: push-in (for $\leq 0.5\text{mm}^2$)

Size: 6 eU (66mm x 72mm)

BBFCP: 1-1-1

Weight: 100g

This module includes four relays with RC-Part and one independent current measurement. Relay 1 consists of a closing contact and can handle a permanent/pulse current of 5/16A. Relay 2 is a switchover contact and handles a permanent/pulse current of 5/8A. Relay 3 and 4 are closing contacts and handle a permanent/pulse current of 4/6A. The current measurement is developed up to 10A eff.

1.2 Connectors and Indication-/Operation-Elements

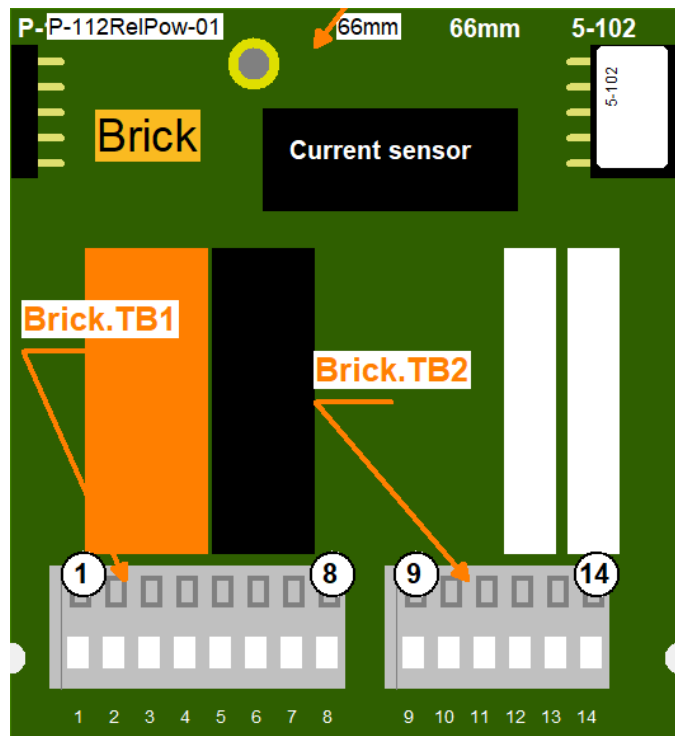

1.2.1 Terminal block (TB)

The following Illustration the technical details for Terminal blocks are listed. The location of a specific block is documented with the ID (left column) in the previous Illustrations.

ID	Model	Model / Series	Grid	Num. of term.	connection	elec. usage
Brick.TB1	Cage Terminal	WAGO250	2.5mm	8	up to 1.5mm ²	signal level
Brick.TB2	Cage Terminal	WAGO250	2.5mm	6	up to 1.5mm ²	signal level

1.2.2 Terminal assignment

Here the assignment of individual terminals and there affiliation to terminal blocks (Te block), terminal numbers (Te no.) and short description (T.desc.) aswell as there electrical function and usage are explained.

The associated mechanical and electrical properties are stated with the specific terminal block in the previous chapter. The position of a terminal is dedicated through the "Te block" and the actual terminal number (Te no.) or the terminal description (T.desc.) in the previous Illustration respectively.

In the column "usage" the technical-/ device-functional use is listed.

Te block	Te no.	T. descr.	Function	Usage
Brick			ind. transformer	AC Current Input
Brick.TB00	0	N	Neutral, Consumer	Rel1
Brick.TB00	1	Lno	Relay, normally open contact, power switching 230V	Rel1

Brick.TB00	2	NC	Relay, normally close contact, isolated	Rel2
Brick.TB00	3	C	Relay, change over contact, isolated	Rel2
Brick.TB00	4	NO	Relay, normally open contact, isolated	Rel2
Brick.TB00	5	NC	Relay, normally close contact, isolated	Rel2
Brick.TB00	6	C	Relay, change over contact, isolated	Rel2
Brick.TB00	7	NO	Relay, normally open contact, isolated	Rel2
Brick.TB00	8	NC	Relay, normally close contact, isolated	Rel2
Brick.TB00	9	C	Relay, change over contact, isolated	Rel2
Brick.TB00	10	NO	Relay, normally open contact, isolated	Rel2

1.2.3 LED Indications

ID	Type	Specification	Type / Usage
Brick.StateLED	SMD-LED	yellow	communicationstate Brick

1.3 Input-/Output Scheme

The following diagram shows the adaption of the control unit. To avoid overlapping, some wires are displayed interrupted and dashed.

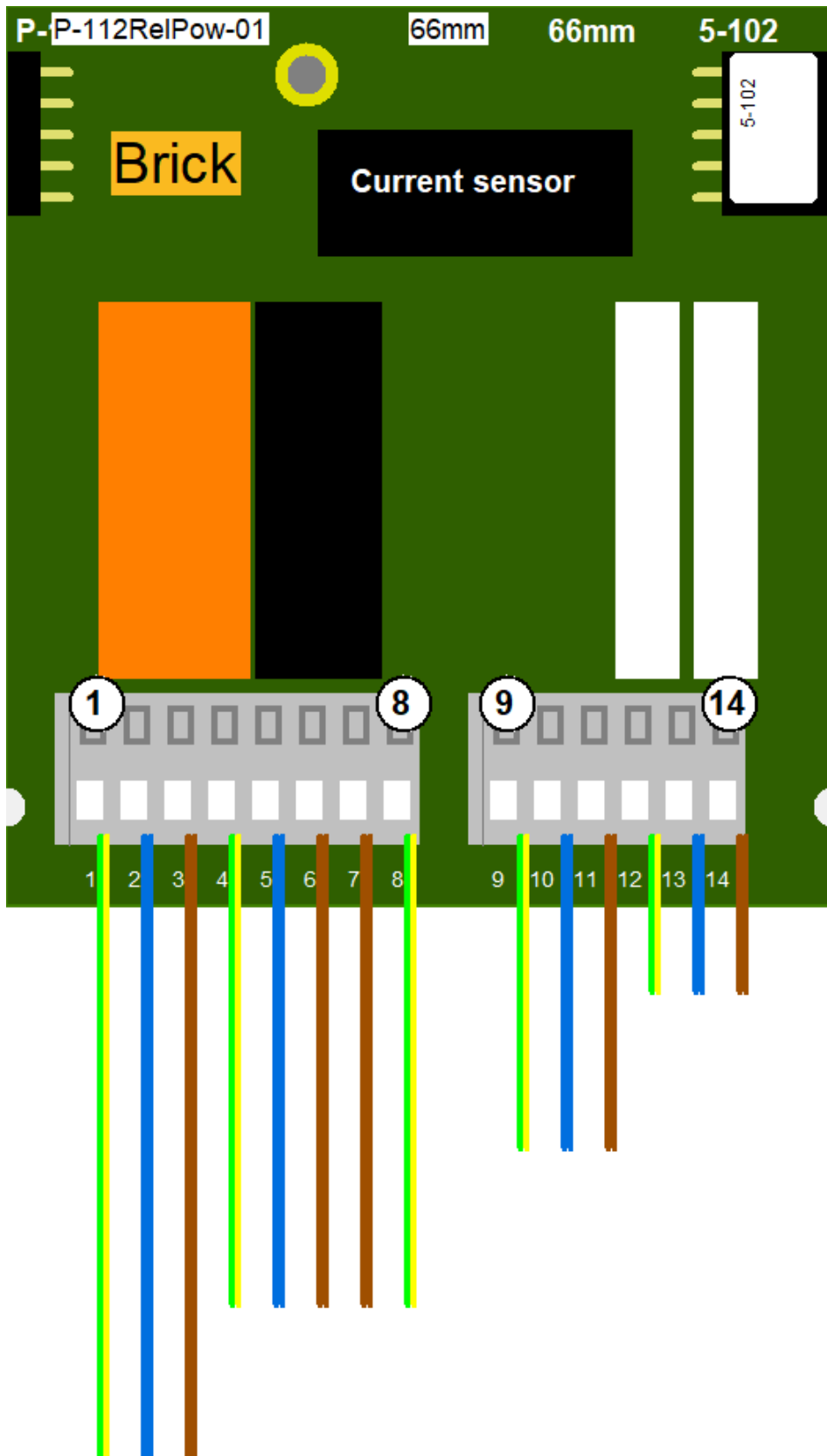

1.4 Technical Data

1.4.1 Digital Outputs

The control unit has the following digital outputs / switching outputs:

Identifier	Rel1
Type	Relay, normally open contact, power switching 230V
max. Switching Volt.	250V AC
max. Switching Cur.	10A AC, Contact 16A
max. Perm. Current	5A AC
nom. Cycles	see datasheet
Component	Schrack, RT33L024
Remark	with snubber

Identifier	Rel2
Type	Relay, change over contact, isolated
max. Switching Volt.	250V AC
max. Switching Cur.	5A AC, Contact 6A
max. Perm. Current	3A AC
nom. Cycles	see datasheet
Component	FTR, LYCA024V
Remark	-

Identifier	Rel2
Type	Relay, change over contact, isolated
max. Switching Volt.	250V AC
max. Switching Cur.	5A AC, Contact 6A
max. Perm. Current	3A AC
nom. Cycles	see datasheet
Component	FTR, LYCA024V
Remark	-

Identifier	Rel2
Type	Relay, change over contact, isolated
max. Switching Volt.	250V AC
max. Switching Cur.	8A AC, contact 10A
max. Perm. Current	5A AC
nom. Cycles	see datasheet
Component	Takamisawa, JS24N-K
Remark	with snubber

1.4.2 Analog Inputs

The control unit has the following analogue inputs / measuring inputs:

Identifier	Rel2
------------	------

Type	Current Sensor
Range	0 ... 20A peak
Input/Load Resistor	-
Resolution	0.5%
Accuracy	2%
Linearity	1%
Filter	-
Linearization	-
Model / Series	ind. transformer
Remark	4% ripple

1.4.3 User Notes

- Blinking behavior StateLED:
Each Morse code is 3 seconds long!
not initialized = flashing continuously at approx. 5Hz
no communication = short-long-short
too little communication = short-short-short
disturbed communication = short-long-long
OK = continuous flashing at approx. 1Hz (0.6-1.5Hz)

1.5 History

On the following page you will find a list of changes that have been made to the product.

1.5.1 History

Date	Entry scope (HW, SWappl, SWapi, Release)	Entry type (enhancement, improvement, bugfix, release)	Version	Status (development, implemented, tested)	Responsible	Reason for the modification	Items of modification	Impact for (end-)customer	Comment	Location in model/source
xxxx-xx-xx		Release	0.99	Tested	NSt					

For questions please contact:

emBrick GmbH	Alfred-Nobel-Straße 2 D-55411 Bingen am Rhein	+49 (0)6721-48035-70	https://www.embrick.de/ https://www.embrick.de/shop/ support@embrick.de
--------------	--	----------------------	--