

# CAE\_P-LfTmp2Pi2AiAo-01

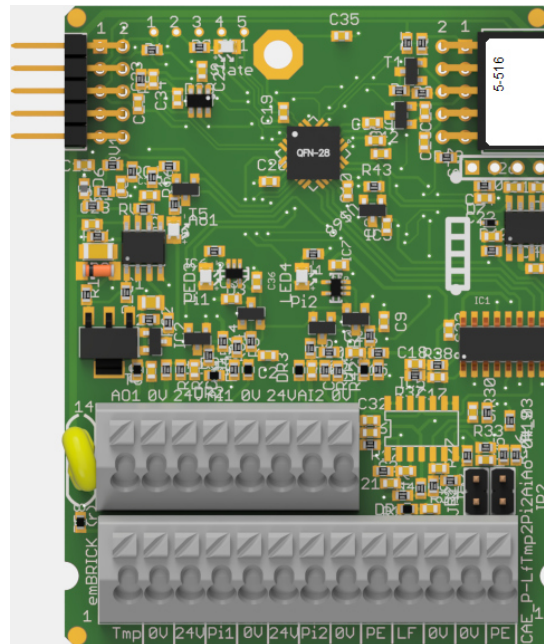

## 1.1 Description

ID: 5-516

Order No.: CAE\_P-LfTmp2Pi2AiAo-01

Terminal: push-in (for  $< 1.5\text{mm}^2$ )

Size: 5 eU (55mm x 72mm)

BBFCP: 1-1-1

Weight: 60g

This module contains all IOs for a typical conductivity measurement with a range of  $1 \dots 4000 \text{ } \mu\text{S/cm}$  (configurable). It supports the common cell constants of  $k = 0.01 \dots 1.0$  (configurable). An integrated temperature input (for PT100,  $-10..50^\circ\text{C}$ ) supplies the necessary temperature compensation. The two special npn pulse input allows the direct adaption of a hall or reed-contact flow and volume sensor from 0.01 up to 250Hz. Additionally two analog voltage ( $0..20\text{mA}$ ) inputs and one analog current ( $0..20\text{mA}$ ) output can be used for other analog sensors/actors.

## 1.2 Connectors and Indication-/Operation-Elements

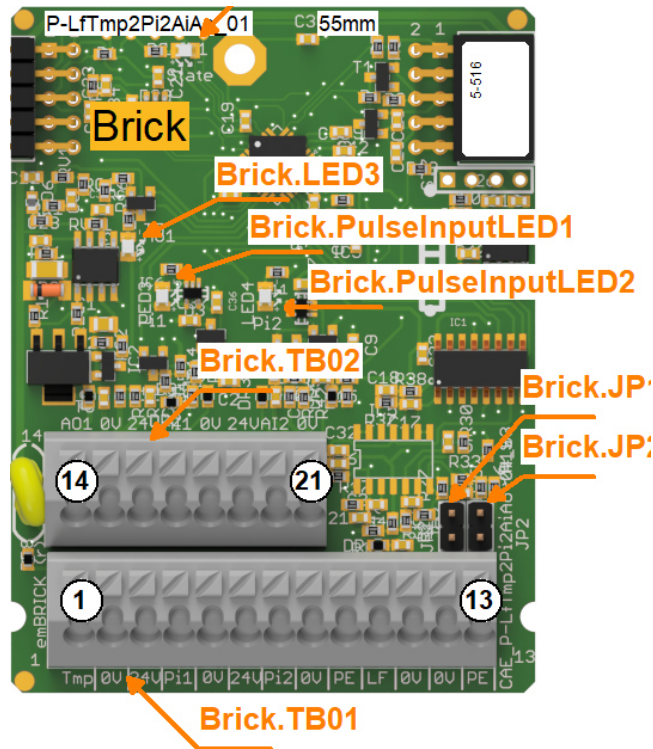

### 1.2.1 Terminal block (TB)

The following Illustration the technical details for Terminal blocks are listed. The location of a specific block is documented with the ID (left column) in the previous Illustrations.

ID	Model	Model / Series	Grid	Num. of term.	connection	elec. usage
Brick.TB01	Cage Terminal	WAGO250	3.5mm	13	up to 1.5mm <sup>2</sup>	signal level
Brick.TB02	Cage Terminal	WAGO250	3.5mm	8	up to 1.5mm <sup>2</sup>	signal level

### 1.2.2 Terminal assignment

Here the assignment of individual terminals and there affiliation to terminal blocks (Te block), terminal numbers (Te no.) and short description (T.desc.) aswell as there electrical function and usage are explained.

The associated mechanical and electrical properties are stated with the specific terminal block in the previous chapter. The position of a terminal is dedicated through the "Te block" and the actual terminal number (Te no.) or the therminal description (T.descr.) in the previous Illustration respectively.

In the column "usage" the technical-/ device-functional use is listed.

Te block	Te no.	T. descr.	Function	Usage
Brick.TB01	1	Tmp	Input Temperature Sensor	Temperature Input
Brick.TB01	2	0V	Ground Sensor	Temperature Input
Brick.TB01	3	V+	Sensor supply +24V	Pulse Input 1

Brick.TB01	4	In	Input	Pulse Input 1
Brick.TB01	5	0V	Ground	Pulse Input 1
Brick.TB01	6	V+	Sensor supply +24V	Pulse Input 2
Brick.TB01	7	In	Input	Pulse Input 2
Brick.TB01	8	0V	Ground	Pulse Input 2
Brick.TB01	9	PE	Shield	Conductivity input
Brick.TB01	10	LF	Input Conductivity Sensor (Cond.)	Conductivity input
Brick.TB01	11	0V	Ground	Conductivity input
Brick.TB01	12	0V	Shield	-
Brick.TB01	13	PE	Shield	-
Brick.TB02	14	OUT	Current Output	Analog output 1
Brick.TB02	15	0V	Ground	Analog output 1
Brick.TB02	16	24V	Sensor supply +24V	Analog input 1
Brick.TB02	17	IN	Input	Analog input 1
Brick.TB02	18	0V	Ground	Analog input 1
Brick.TB02	19	24V	Sensor supply +24V	Analog input 2
Brick.TB02	20	IN	Input	Analog input 2
Brick.TB02	21	0V	Ground	Analog input 2

### 1.2.3 Jumper overview (JP)

The individual jumpers, their combination to logical jumper groups and their usage are stated below. The location of individual jumpers is determined through the jumper ID (left column) in the previous illustrations.

ID	Jumper Block	Usage
Brick.JP01	Brick.JP-LF	Cond. Range Selection
Brick.JP02	Brick.JP-LF	Cond. Range Selection

### 1.2.4 Jumpergroups and configuration

Hereafter possible jumper groups settings are described. They refer to jumper-ID of the previous listings. A "o" symbolises a disconnected jumper, a "x" symbolises a connected jumper.

Jumper Block	Selections	Effect
Brick.JP-LF	A: JP1=o JP2=o B: JP1=x JP2=o C: JP1=o JP2=x	Selection of the possible measuring range: Depending on which measuring range you want to measure, the jumper must be plugged in accordingly. This depends firstly on the K value of the probe used and secondly on the set measurement gain.  Example:  Probe with a K-value of 1.0 Conductivity to be measured max. Approx. 1000µS / cm  From the list below, option B would be suitable. Jumper 1 must be plugged in and the Meas.-Ampl./Gain set to 10% in the

		<p>Conductivity Sensor menu so that a measurement range up to 1000 <math>\mu\text{S}/\text{cm}</math> can be measured with a <math>K = 1.0</math> probe.</p> <p>A: 250<math>\mu\text{S}/\text{cm}</math> (<math>K=1.0</math> with Meas.-Ampl./Gain = 10%), ADC-Value: approx. 395  25<math>\mu\text{S}/\text{cm}</math> (<math>K=0.1</math> with Meas.-Ampl./Gain = 10%), ADC-Value: approx. 395  25<math>\mu\text{S}/\text{cm}</math> (<math>K=1.0</math> with Meas.-Ampl./Gain = 100%), ADC-Value: approx. 395</p> <p>B: 1000<math>\mu\text{S}/\text{cm}</math> (<math>K=1.0</math> with Meas.-Ampl./Gain = 10%), ADC-Value: approx. 410  100<math>\mu\text{S}/\text{cm}</math> (<math>K=0.1</math> with Meas.-Ampl./Gain = 10%), ADC-Value: approx. 410  100<math>\mu\text{S}/\text{cm}</math> (<math>K=1.0</math> with Meas.-Ampl./Gain = 100%), ADC-Value: approx. 410</p> <p>C: 4300<math>\mu\text{S}/\text{cm}</math> (<math>K=1.0</math> with Meas.-Ampl./Gain = 10%), ADC-Value: approx. 410  430<math>\mu\text{S}/\text{cm}</math> (<math>K=0.1</math> with Meas.-Ampl./Gain = 10%), ADC-Value: approx. 410</p> <p>The jumper is usually plugged once into the basic configuration of the device.  If the jumper is changed after calibrations have been made, they must be redone.</p>
--	--	---

### 1.2.5 LED Indications

ID	Type	Specification	Type / Usage
Brick.LED01	SMD-LED	green	Shows state of Pulse Input 1
Brick.LED02	SMD-LED	green	Shows state of Pulse Input 2
Brick.LED03	SMD-LED	green	Shows state of Analog output 1
Brick.StateLED	SMD-LED	yellow	communicationstate Brick

### 1.3 Input-/Output Scheme

The following diagram shows the adaption of the control unit. To avoid overlapping, some wires are displayed interrupted and dashed.

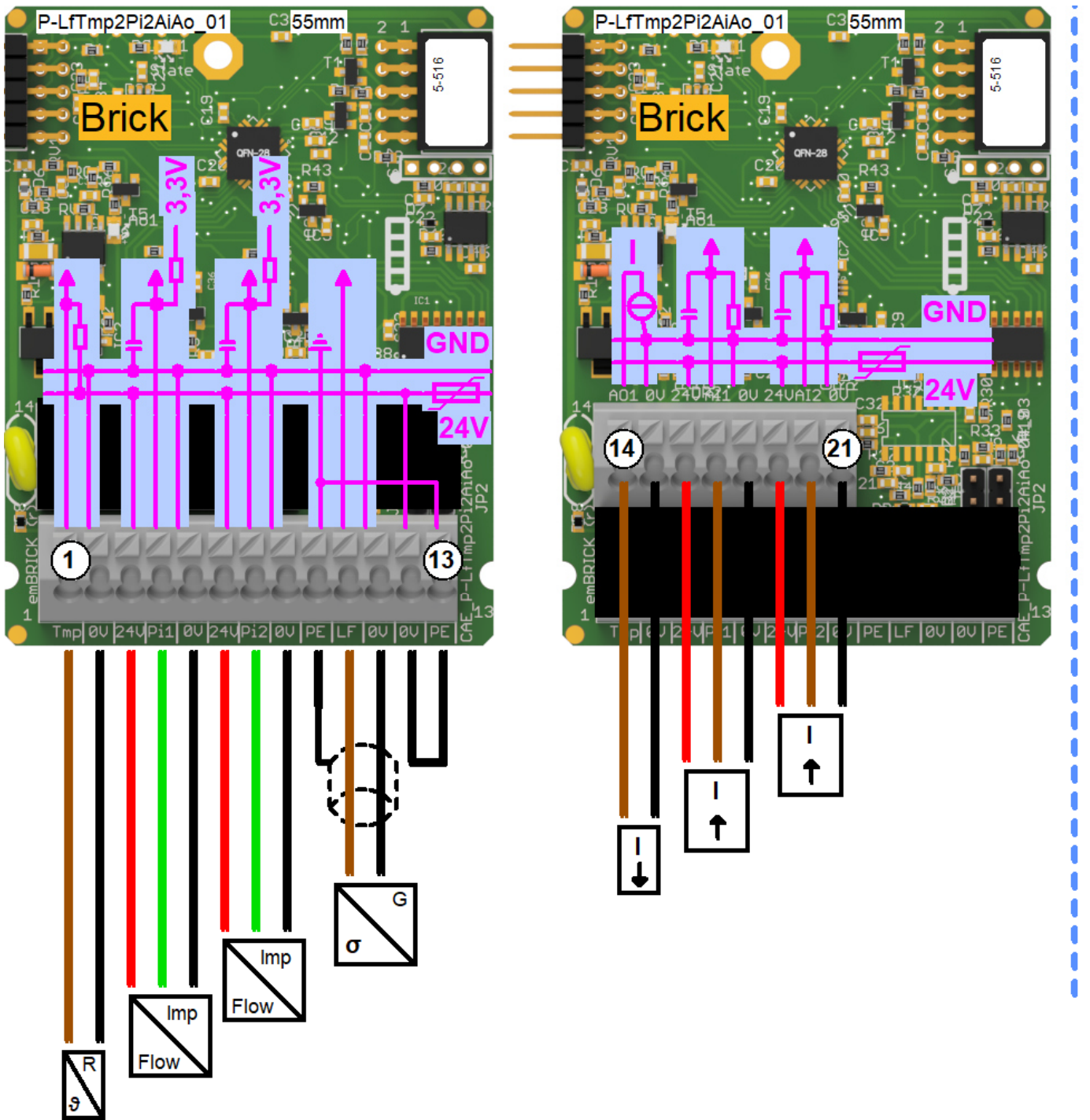

## 1.4 Technical Data

### 1.4.1 Analog Inputs

The control unit has the following analogue inputs / measuring inputs:

Identifier	Analog input 1
Type	Current Input
Range	0/4 ... 20mA, 2/3-wire
Input/Load Resistor	175 Ohm
Resolution	10Bit
Accuracy	0.5%
Linearity	0.2%
Filter	-
Linearization	-
Model / Series	-
Remark	-

Identifier	Analog input 2
Type	Current Input
Range	0/4 ... 20mA, 2/3-wire
Input/Load Resistor	175 Ohm
Resolution	10Bit
Accuracy	0.5%
Linearity	0.2%
Filter	-
Linearization	-
Model / Series	-
Remark	-

Identifier	Conductivity input
Type	Conductivity, conductive sensor
Range	0 ... 5000 $\mu$ S/cm @ K=1.0
Input/Load Resistor	-
Resolution	0.2%
Accuracy	2%
Linearity	1%
Filter	Tau = 1s
Linearization	Temperature compensation 2.2%/K
Model / Series	for cell constant K=0.01 ... 10
Remark	-

Identifier	Temperature Input
Type	Temperature input, PT1000, 0...50°C
Range	0 ... 50°C
Input/Load Resistor	-
Resolution	0.1%
Accuracy	2%
Linearity	1%
Filter	Tau = 1s

Linearization	-
Model / Series	PT1000
Remark	-

### 1.4.2 Analog Outputs

The control unit has the following analog outputs:

Identifier	Analog output 1
Type	Current Output
Range	0 ... 20mA
max. Voltage	$V_o < 12V$
max. Current	25mA
Filter	1st order, fcut off = approx. 2Hz
Component	-
Remark	Load Resistor 0...600 Ohm

### 1.4.3 Pulse and Counting Inputs

The control unit has the following pulse inputs / counter inputs:

Identifier	Pulse Input 1
Type	Impuls/Digital input, universal 2/3 wire
Threshold	0.6 / 1V
Input Circuit	n-switching
Sensitivity	rising slope
Gate Time (Frequ.Mode)	10ms ... 65s
Resolution (Per.Mode)	1 ... 50ms
Filter	hardware, 1st order, fcut off = approx. 1.5kHz
Component	-
Remark	Sensor power supply (24V) is provided; note overall capacity

Identifier	Pulse Input 2
Type	Impuls/Digital input, universal 2/3 wire
Threshold	0.6 / 1V
Input Circuit	n-switching
Sensitivity	rising slope
Gate Time (Frequ.Mode)	10ms ... 65s
Resolution (Per.Mode)	1 ... 50ms
Filter	hardware, 1st order, fcut off = approx. 1.5kHz
Component	-
Remark	Sensor power supply (24V) is provided; note overall capacity

#### 1.4.4 Fuses

The controller owns the following internal fuses for providing safety for the device and partially for the connected sensors/ actors:

ID	Type	Nom. Current	Characteristic	Usage
Brick.SI 1	Polyfuse	100mA		Sensor supply +24V

#### 1.4.5 User Notes

- Blinking behavior StateLED:  
Each Morse code is 3 seconds long!  
not initialized = flashing continuously at approx. 5Hz  
no communication = short-long-short  
too little communication = short-short-short  
disturbed communication = short-long-long  
OK = continuous flashing at approx. 1Hz (0.6-1.5Hz)

#### 1.4.6 Developer Notes

- For chattering switching contacts on slow frequencies, the configurable filter should be used. On higher frequencies the filter isn't available; therefore a semiconductor contact is recommended.
- Make sure that the GND of the analog signals is connected to the 0V clamp. Otherwise the measurement will reduce precision.
- The shield of the sensor should be connected to PE over the PE connector.
- With the shield bridge you can choose whether you connect the shield, of your sensor line directly, on GND or you can only connect it over the PE-pin (13) with PE in your system.

#### 1.4.7 Technican Notes

- Bus power consumption: sensor supply + analog Output + 5mA@24V,

## 1.5 Process Data Image

### 1.5.1 Outgoing Process Data (from bus master to this brick)

Byte	Function	rCAssign
00..01	Analog_Output 1 0..12900 Dig.= 0..20mA	...+eB_W0,0,...
02..03	Cond-Measuring Voltage 0...16000 Dig. ≡ 0...100%	...+eB_W1,0,...
04..05	Cond. Measuring Mode Bit 3-0 ...SS: Sample Start Value (Little Endian) 1, 2, ... ,15 = 1%, 5%, 9 %, ..., 57% (0=default 40 %) Bit 7-4 ...SE: Sample End Value (Little Endian) 1, 2, ... ,15 = 5%, 9%, 13 %, ..., 61% (0=default 80 %) Bit 10-8 ...MF: Measuring Frequency 000 = 1 kHz (default) 001 = 2 kHz 010 = 4 kHz 011 = 8 kHz 100 = 500 H 101 = 250 Hz 110 = unused 111 = unused	...+eB_W2,0,...
06..07	unused	...+eB_W3,0,...
08..09	Pulse Input Control 1 Bit 15-10 ...MODE: Pulse Input operating Mode 110010 = Mode Period Duration with Time Grid 50ms 110001 = Mode Period Duration with Time Grid 49ms ... 000010 = Mode Period Duration with Time Grid 2ms 000001 = Mode Period Duration with Time Grid 1ms 000000 = Mode Fixed Gate Time  Bit 9-0 ...MSET: Mode Settings in Mode "Period Duration": Filter Period in ms, to filter out con-tact chattering (Little Endian): 11 1111 1111 = Filter Period 1023ms ... 00 0000 0000 = Filter Period 0ms In Mode "Fixed Gate Time" Mode Settings has no effect	...+eB_W4,0,...
10..11	Pulse Input Attribute 1 Bit 15-0: ...ATTR: Additional Pulse Input Attributes in Mode "Period Duration": Timeout for 0-setting (Little Endian): 1111 1111 1111 1111 = 65535 * Time Grid ... 0000 0000 0000 0000 = 0 in Mode "Fixed Gate Time": Gate Time in ms (Little Endian): 1111 1111 1111 1111 = 65535ms ... 0000 0000 0000 0000 = 0ms	...+eB_W5,0,...
12..13	Pulse Input Control 2	...+eB_W6,0,...
14..15	Pulse Input Attribute 2 See Pulse Input Attribute 1.	...+eB_W7,0,...

### 1.5.2 Incoming Process Data (from this brick to the bus master)

Byte	Function	rCAssign																																													
00..01	<p>Analog Input Conductance</p> <p>The indicated measuring end ranges refers to the given jumper configuration, cell constant and measuring amplitude.</p> <table border="1"> <thead> <tr> <th>jumper configuration.</th> <th>measured conductance</th> <th colspan="2">corresponds to a sensor value conductivity in medium</th> <th>measured conductivity</th> <th>with a measuring amplitude of ...</th> </tr> <tr> <td></td> <td>approx.</td> <td>approx.</td> <td>cell constant</td> <td>approx.</td> <td></td> </tr> </thead> <tbody> <tr> <td rowspan="2">jumper JP2</td> <td rowspan="2">4300<math>\mu</math>S</td> <td>4300 <math>\mu</math>S/cm</td> <td>K = 1.0</td> <td rowspan="2">410</td> <td>10 %</td> </tr> <tr> <td>430 <math>\mu</math>S/cm</td> <td>K = 0.1</td> <td>10 %</td> </tr> <tr> <td rowspan="3">jumper JP1</td> <td rowspan="3">1000<math>\mu</math>S</td> <td>1000 <math>\mu</math>S/cm</td> <td>K = 1.0</td> <td rowspan="3">410</td> <td>10 %</td> </tr> <tr> <td>100 <math>\mu</math>S/cm</td> <td>K = 0.1</td> <td>10 %</td> </tr> <tr> <td>100 <math>\mu</math>S/cm</td> <td>K = 1.0</td> <td>100 %</td> </tr> <tr> <td rowspan="3">no jumper</td> <td rowspan="3">250<math>\mu</math>S</td> <td>250 <math>\mu</math>S/cm</td> <td>K = 1.0</td> <td rowspan="3">395</td> <td>10 %</td> </tr> <tr> <td>25 <math>\mu</math>S/cm</td> <td>K = 0.1</td> <td>10 %</td> </tr> <tr> <td>25 <math>\mu</math>S/cm</td> <td>K = 1.0</td> <td>100 %</td> </tr> </tbody> </table> <p>Note: The measured conductivity has an offset of 3 ... 8 digits. Therefore an initial zero point calibration (one time, independent of sensor) by software is recommended.</p> <p>Note: The delivery state of the jumpers are JP2 is set.</p> <p>The measuring range can be made proportionally more sensitive (less sensitive) by increasing (decreasing) the measuring amplitude. More sensitivity means the same measured value (or a higher value) at less (or the same) sensor conductivity in the medium.</p>	jumper configuration.	measured conductance	corresponds to a sensor value conductivity in medium		measured conductivity	with a measuring amplitude of ...		approx.	approx.	cell constant	approx.		jumper JP2	4300 $\mu$ S	4300 $\mu$ S/cm	K = 1.0	410	10 %	430 $\mu$ S/cm	K = 0.1	10 %	jumper JP1	1000 $\mu$ S	1000 $\mu$ S/cm	K = 1.0	410	10 %	100 $\mu$ S/cm	K = 0.1	10 %	100 $\mu$ S/cm	K = 1.0	100 %	no jumper	250 $\mu$ S	250 $\mu$ S/cm	K = 1.0	395	10 %	25 $\mu$ S/cm	K = 0.1	10 %	25 $\mu$ S/cm	K = 1.0	100 %	...+eB_W0,0,...
jumper configuration.	measured conductance	corresponds to a sensor value conductivity in medium		measured conductivity	with a measuring amplitude of ...																																										
	approx.	approx.	cell constant	approx.																																											
jumper JP2	4300 $\mu$ S	4300 $\mu$ S/cm	K = 1.0	410	10 %																																										
		430 $\mu$ S/cm	K = 0.1		10 %																																										
jumper JP1	1000 $\mu$ S	1000 $\mu$ S/cm	K = 1.0	410	10 %																																										
		100 $\mu$ S/cm	K = 0.1		10 %																																										
		100 $\mu$ S/cm	K = 1.0		100 %																																										
no jumper	250 $\mu$ S	250 $\mu$ S/cm	K = 1.0	395	10 %																																										
		25 $\mu$ S/cm	K = 0.1		10 %																																										
		25 $\mu$ S/cm	K = 1.0		100 %																																										
02..03	<p>Analog Input Temp</p> <p>77...872 Dig. <math>\equiv</math> 0...100 <math>^{\circ}</math>C <math>\equiv</math> 100 und 138,5 Ohm</p>	...+eB_W1,0,...																																													
04..05	<p>Analog-Input 1</p> <p>0...894 Dig. <math>\equiv</math> 0...20 mA ... or 0...933 Dig. <math>\equiv</math> 0...10 V</p>	...+eB_W2,0,...																																													
06..07	<p>Analog-Input 2</p> <p>0...894 Dig. <math>\equiv</math> 0...20 mA ... or 0...933 Dig. <math>\equiv</math> 0...10 V</p>	...+eB_W3,0,...																																													
08..09	<p>Puls Input Sum 1</p> <p>Bit 15-14 ...TR: Time Reference; 2 Bit Counter that counts up every millisecond. Can be used to compensate the clock deviation of the emBRICK®-module.</p> <p>Bit 13-0 ...Pulse Input Sum Value; Increments on falling edge; Resets to zero on overflow (Little Endian): 11 1111 1111 1111 = 16383 ...00 0000 0000 0000 = 0</p>	...+eB_W4,0,...																																													
10..11	<p>Puls Input Difference 1</p> <p>Bit 15-0 ...PIDV: Pulse Input Difference Value in Mode "Fixed Gate Time": Displays all fallen edges monitored in the timeframe defined in Pulse Input Attribute x</p>	...+eB_W5,0,...																																													
12..13	<p>Puls Input Sum 2</p> <p>See Puls Input Sum 1</p>	...+eB_W6,0,...																																													
14..15	<p>Puls Input Difference 2</p> <p>See Puls Input Difference 1</p>	...+eB_W7,0,...																																													
16	<p>Input Image</p> <p>Bit 0 = dig. status of counter 1 Bit 1 = dig. status of counter 2 Bit 2 = dig. status of Analog-Input1 Bit 3 = dig. status of Analog-Input2</p>	<p>...+eB_B16,0,...</p> <p>...+eB_B16,1,...</p> <p>...+eB_B16,2,...</p> <p>...+eB_B16,3,...</p> <p>...+eB_B16,4,...</p> <p>...+eB_B16,5,...</p> <p>...+eB_B16,6,...</p> <p>...+eB_B16,7,...</p>																																													

## 1.6 History

On the following page you will find a list of changes that have been made to the product.

### 1.6.1 History

Date	Entry scope (HW, SWappl, SWapi, Release)	Entry type (enhancement, improvement, bugfix, release)	Version	Status (development, implemented, tested)	Responsible	Reason for the modification	Items of modification	Impact for (end-)customer	Comment	Location in model/source
xxxx-xx-xx		Release	0.99	Tested	NSt					

For questions please contact:

emBrick GmbH	Alfred-Nobel-Straße 2 D-55411 Bingen am Rhein	+49 (0)6721-48035-70	<a href="https://www.embrick.de/">https://www.embrick.de/</a> <a href="https://www.embrick.de/shop/">https://www.embrick.de/shop/</a> <a href="mailto:support@embrick.de">support@embrick.de</a>
--------------	--	----------------------	--