

CAE_P-UlcTmpAoDAioImp-01

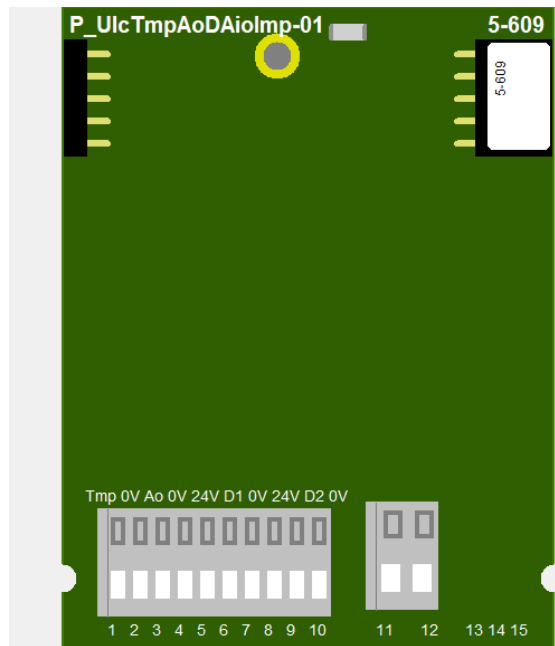

1.1 Description

ID: 5-609

Order No.: CAE_P-UlcTmpAoDAioImp-01

Terminal: push-in (for $\leq 0.5\text{mm}^2$)

Size: 5eU (55mm x 72mm)

BBFCP: 1-1-1

Weight: 40g

Offers a 0 ... 300mV ultra low current voltage input, fully galvanic isolated for operation of e.g. with chemical probes. The assignment is 0 ... 300mV => 30...980 digits.

1.2 Connectors and Indication-/Operation-Elements

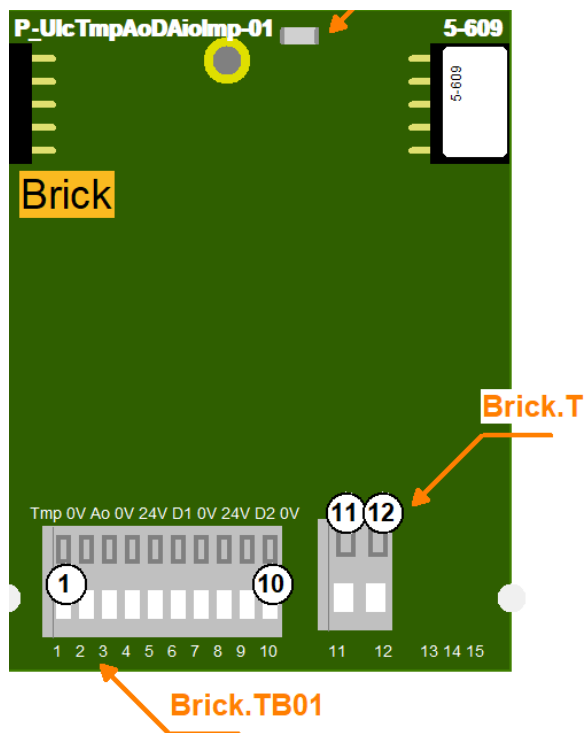

1.2.1 Terminal block (TB)

The following Illustration the technical details for Terminal blocks are listed. The location of a specific block is documented with the ID (left coloumn) in the preavious Illustrations.

ID	Model	Model / Series	Grid	Num. of term.	connection	elec. usage
Brick.TB1	Cage Terminal	WAGO250	2.5mm	10	up to 0.5mm ² or 0,8mm	signal level
Brick.TB2	Cage Terminal	WAGO250	2.5mm	2	up to 1.5mm ²	signal level

1.2.2 Terminal assignment

Here the assignment of individual terminals and there affiliation to terminal blocks (Te block), terminal numbers (Te no.) and short description (T.desc.) aswell as there electrical function and usage are explained.

The associated mechanical and electrical properties are stated with the specific terminal block in the previous chapter. The position of a terminal is dedicated through the "Te block" and the actual terminal number (Te no.) or the therminal description (T.descr.) in the previous Illustration respectively.

In the coloumn "usage" the technical-/ device-functional use is listed.

Te block	Te no.	T. descr.	Function	Usage
Brick.TB00	0	24V	Sensor supply +24V	Voltage Input
Brick.TB00	1	IN	Input	Voltage Input

Brick.TB00	2	0V	Ground	Voltage Input
Brick.TB00	3	V+	Sensor supply +24V	AnIn1
Brick.TB00	4	In	Input	AnIn1
Brick.TB00	5	0V	Ground	AnIn1
Brick.TB00	6	24V	Sensor supply +24V	AnIn1
Brick.TB00	7	IN	Input	AnIn1
Brick.TB00	8	0V	Ground	AnIn1
Brick.TB00	9	OUT	Current Output	AnOut1
Brick.TB00	10	0V	Ground	AnOut1
Brick.TB00	11	Tmp	Input Temperature Sensor	Temp1
Brick.TB00	12	0V	Ground Sensor	Temp1

1.2.3 LED Indications

ID	Type	Specification	Type / Usage
Brick.StateLED	SMD-LED	yellow	communicationstate Brick

1.4 Technical Data

1.4.1 Analog Inputs

The control unit has the following analogue inputs / measuring inputs:

Identifier	AnIn1
Type	Current Input
Range	0/4 ... 20mA, 2/3-wire
Input/Load Resistor	175 Ohm
Resolution	10Bit
Accuracy	0.5%
Linearity	0.2%
Filter	-
Linearization	-
Model / Series	-
Remark	-

Identifier	Temp1
Type	Temperature input, PT1000, 0...50°C
Range	0 ... 50°C
Input/Load Resistor	-
Resolution	0.1%
Accuracy	2%
Linearity	1%
Filter	Tau = 1s
Linearization	-
Model / Series	PT1000
Remark	-

Identifier	Voltage Input
Type	Voltage Input
Range	0 ... 10V
Input/Load Resistor	>50k
Resolution	
Accuracy	0.5%
Linearity	0.2%
Filter	100Hz
Linearization	
Model / Series	
Remark	Sensor power supply (24V) is provided; note overall capacity

1.4.2 Analog Outputs

The control unit has the following analog outputs:

Identifier	AnOut1
------------	--------

Type	Current Output
Range	0 ... 20mA
max. Voltage	$V_o < 12V$
max. Current	25mA
Filter	1st order, $f_{cut\ off} = \text{approx. } 2Hz$
Component	-
Remark	Load Resistor 0...600 Ohm

1.4.3 Pulse and Counting Inputs

The control unit has the following pulse inputs / counter inputs:

Identifier	AnIn1
Type	Impuls/Digital input, universal 2/3 wire
Threshold	0.6 / 1V
Input Circuit	n-switching
Sensitivity	rising slope
Gate Time (Frequ.Mode)	10ms ... 65s
Resolution (Per.Mode)	1 ... 50ms
Filter	hardware, 1st order, $f_{cut\ off} = \text{approx. } 1.5kHz$
Component	-
Remark	Sensor power supply (24V) is provided; note overall capacity

1.4.4 Fuses

The controller owns the following internal fuses for providing safety for the device and partially for the connected sensors/ actors:

ID	Type	Nom. Current	Characteristic	Usage
Brick.SI 0	PolyFuse	100mA		Sensor supply +24V
Brick.SI 1	PolyFuse	100mA		isolated sensor supply +12V

1.4.5 User Notes

- Blinking behavior StateLED:
Each Morse code is 3 seconds long!
not initialized = flashing continuously at approx. 5Hz
no communication = short-long-short
too little communication = short-short-short
disturbed communication = short-long-long

OK = continuous flashing at approx. 1Hz (0.6-1.5Hz)

1.5 History

On the following page you will find a list of changes that have been made to the product.

1.5.1 History

Date	Entry scope (HW, SWappl, SWapi, Release)	Entry type (enhancement, improvement, bugfix, release)	Version	Status (development, implemented, tested)	Responsible	Reason for the modification	Items of modification	Impact for (end-)customer	Comment	Location in model/source
xxxx-xx-xx		Release	0.99	Tested	NSt					

For questions please contact:

emBrick GmbH	Alfred-Nobel-Straße 2 D-55411 Bingen am Rhein	+49 (0)6721-48035-70	https://www.embrick.de/ https://www.embrick.de/shop/ support@embrick.de
--------------	--	----------------------	--